

Bachelor of Science

Marketing 2009-2010

Audit Worksheet

Name: _____

M # _____

e-mail: _____

Grad. Term: _____

Core Requirements

BA 1100	Introduction to Business	3	
BA 1200	IS/IT Fundamentals	3	
BA 2110	Quantitative Problem Solving	3	
BA 2330	Accounting 1	3	
BA 2340	Accounting 2	3	
BA 2500	Business Law	3	
BA 2700	Business Problem Solving	3	
BA 3200	IS/IT Management	3	
BA 3400	Principles of Finance	3	
BA 3610	Operations Management	3	
BA 3700	Organizational Behavior	3	
BA 3800	Principles of Marketing	3	
BA 4700	Strategic Management	3	
EC 2001	Principles of Economics	3	
EC 3300	Industrial Organization	3	

Credit Total **45**

Math Requirements

MA 1030	and	College Algebra I	3	
MA 1031		College Algebra II with Trig	3	
MA 1032	or	Data, Functions, & Graphs Plus	4	
MA 1135	or	Calculus for Life Sciences	4	
MA 1160		Calculus with Technology I	4	
MA 2720		Statistical Methods	4	

Credit Total **8-14**

Lab Science Requirements

BL / Biology , CH / Chemistry , FW / Forestry GE / Geology , PH / Physics			

Credit Total **3-4**

Major Requirements

BA 3620	Project Management	3	
BA 4800	Business Research	3	
BA 4860	Buyer Behavior and E-Commerce	3	

Credit Total **9**

Major Electives (*choose 3*)

BA 3780	Entrepreneurship	3	
BA 3900	Business Internship	1 - 4	
BA 4620	Supply Chain Management	3	
BA 4630	Operations Strategy	3	
BA 4840	Industrial Marketing	3	
BA 4870	Advertising/Sales Promotion	3	
BA 4880	Sales and Sales Management	3	

Credit Total **9**

General Education Requirements

Credit Count

UN 1001	Perspectives	3	
UN 1002**	World Cultures	4	
UN 2001	Revisions	3	
UN 2002	Institutions	3	
<i>Credit Total 13</i>			
<i>**Two semesters of a single modern language (6 c) in addition to UN 1003 (1 c) can substitute for UN 1002 + 3 credits of HASS requirements</i>			
HASS Distribution Courses			
<i>No more than 3 credits from HASS Creative Endeavors List may be used</i>			
<i>No more than 3 credits from the HASS Supplemental List may be used</i>			
EC3100	International Economics	3	
<i>Credit Total 15</i>			
Co-curricular Activities (units)			
		0.5	
		0.5	
		0.5	
		0.5	
		0.5	
		0.5	
Free Electives			
<i>19 - 26 Free Elective credits of Choice</i>			
<i>Credit Total 19 - 26</i>			

- Semester 1 _____
- Semester 2 _____
- Semester 3 _____
- Semester 4 _____
- Semester 5 _____
- Semester 6 _____
- Semester 7 _____
- Semester 8 _____
- Semester 9 _____
- Semester 10 _____

Total Required Credits 128



MARKETING



FIRST YEAR

SECOND YEAR

THIRD YEAR

FOURTH YEAR

FALL

SPRING

FALL

SPRING

FALL

SPRING

FALL

SPRING

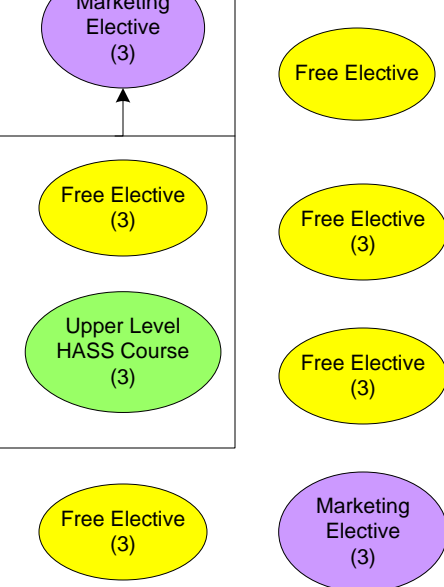
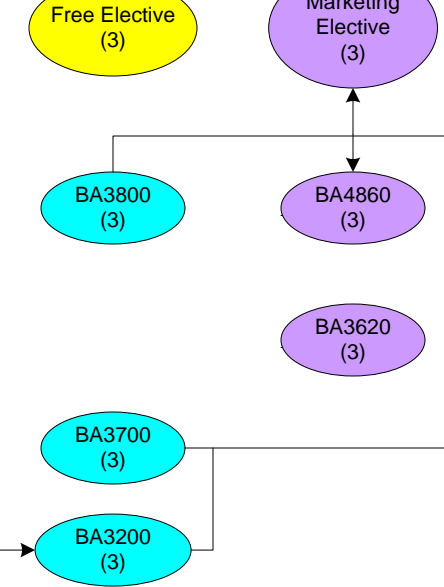
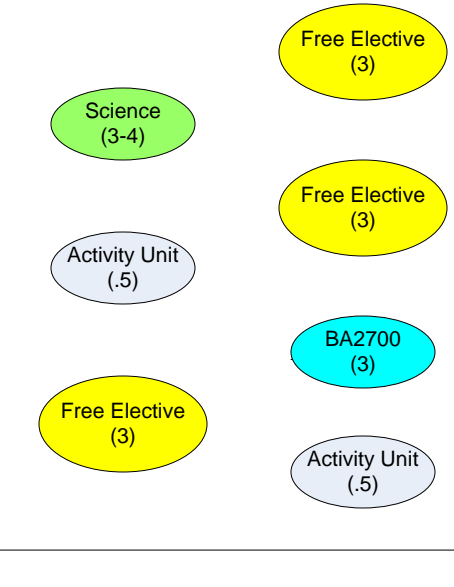
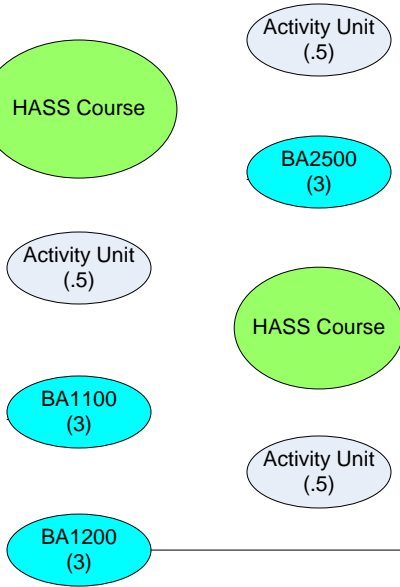
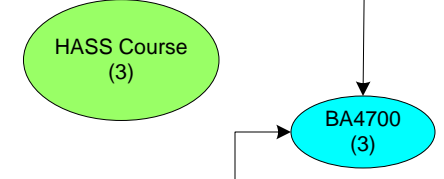
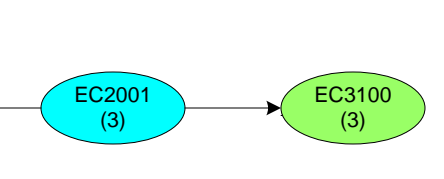
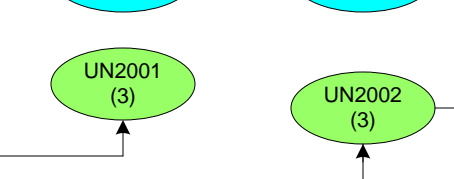
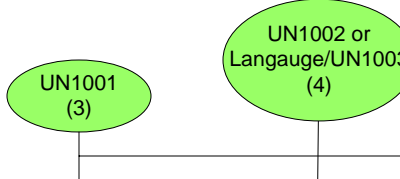
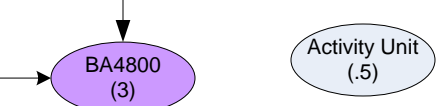
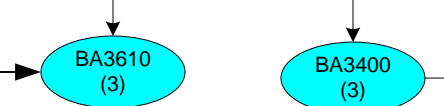
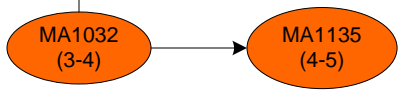

15-16

14-15

16-17

18

18

15

18

15

KEY Prerequisite General Education Business Core Mathematics Concentration Free Electives